

SMD - Resistors

Product : Thin Film Precision Chip Resistor - SMDT Series

Size: 0201/0402/0603/0805/1206/1210/2010/2512



official distributor of



SMD - Resistors

Thin Film Precision Chip Resistor (SMDT Series)

► 1. Features

- Advanced thin film technology
- Very tight tolerance down to $\pm 0.01\%$
- Extremely low TCR down to $\pm 2\text{PPM}/^\circ\text{C}$
- Wide resistance range 1ohm ~ 3Mega ohm
- Miniature size 0201 available

► 2. Applications

- Medical Equipment
- Testing / Measurement Equipment
- Printer Equipment
- Automatic Equipment Controller
- Converters
- Communication Device, Cell Phone, GPS, PDA

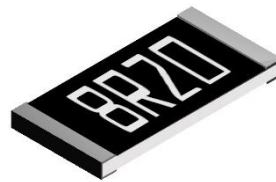

► 3. Construction

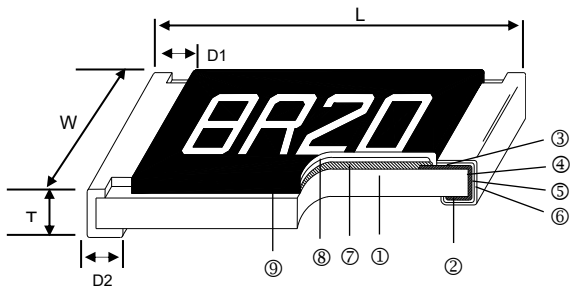

① Alumina Substrate	③ Edge Electrode (NiCr)	⑤ Resistor Layer (NiCr)
② Bottom Electrode (Ag)	④ Barrier Layer (Ni)	⑥ Overcoat (Epoxy)
③ Top Electrode (Ag)	⑥ External Electrode (Sn)	⑨ Marking

► 4. Dimensions

Unit: mm

Type	Size (Inch)	L	W	T	D1	D2	Weight (g) (1000pcs)
SMDT0201	0201	0.58 \pm 0.05	0.29 \pm 0.05	0.23 \pm 0.05	0.12 \pm 0.05	0.15 \pm 0.05	0.14
SMDT0402	0402	1.00 \pm 0.05	0.50 \pm 0.05	0.30 \pm 0.05	0.20 \pm 0.10	0.20 \pm 0.10	0.54
SMDT0603	0603	1.55 \pm 0.10	0.80 \pm 0.10	0.45 \pm 0.10	0.30 \pm 0.20	0.30 \pm 0.20	1.83
SMDT0805	0805	2.00 \pm 0.15	1.25 \pm 0.15	0.55 \pm 0.10	0.30 \pm 0.20	0.40 \pm 0.25	4.71
SMDT1206	1206	3.05 \pm 0.15	1.55 \pm 0.15	0.55 \pm 0.10	0.42 \pm 0.20	0.35 \pm 0.25	9.02
SMDT1210	1210	3.10 \pm 0.15	2.40 \pm 0.15	0.55 \pm 0.10	0.40 \pm 0.20	0.55 \pm 0.25	10
SMDT2010	2010	4.90 \pm 0.15	2.40 \pm 0.15	0.55 \pm 0.10	0.60 \pm 0.30	0.50 \pm 0.25	23.61
SMDT2512	2512	6.30 \pm 0.15	3.10 \pm 0.15	0.55 \pm 0.10	0.60 \pm 0.30	0.50 \pm 0.25	38.06

SMD - Resistors

► 5. Part Numbering

SMDT	0603	T	T	B	Y	1001	N
Product Type	Dimensions (L×W)	Resistance Tolerance	Packaging Code	TCR (PPM/°C)	Power Rating	Resistance	Marking Code
	0201 0402 0603 0805 1206 1210 2010 2512	T: ±0.01% A: ±0.05% B: ±0.1% C: ±0.25% D: ±0.5% F: ±1%	T: Taping Reel B: Bulk	5: ±1 X: ±2 O: ±3 S: ±5 B: ±10 N: ±15 C: ±25 D: ±50	: Standard Y: 1/16W X: 1/10W W: 1/8W M: 1/6W P: 1/5W V: 1/4W O: 1/3W U: 1/2W Q: 3/4W T: 1W	0010: 1Ω 4R70: 4.7Ω 1001: 1KΩ 1004: 1MΩ	: Standard Marking for E96 / E24 N: No Marking

► 6. Derating Curve

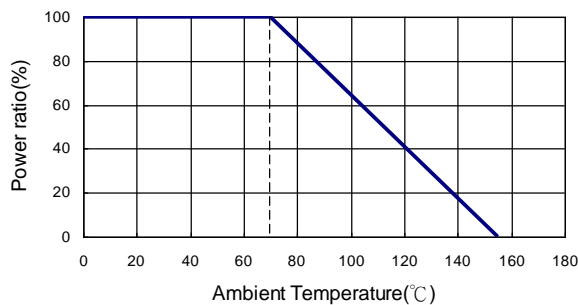

► 7. Standard Electrical Specifications

Item Type	Power Rating at 70°C	Operating Temp. Range	Max. Operating Voltage	Max. Overload Voltage	Resistance Range					TCR (PPM/°C)
					±0.05%	±0.1%	±0.25%	±0.5%	±1%	
SMDT0201	1/32W	-55 ~ +155°C	15V	30V	-					±25 ±50
SMDT0402	1/16W	-55 ~ +155°C	25V	50V	49.9Ω - 12KΩ	10Ω - 511KΩ	4.7Ω - 511KΩ			±25 ±50
SMDT0603	1/16W	-55 ~ +155°C	50V	100V	4.7Ω - 332KΩ	4.7Ω - 1MΩ	1Ω - 1MΩ			±25 ±50
SMDT0805	1/10W	-55 ~ +155°C	100V	200V	4.7Ω - 1MΩ	4.7Ω - 2MΩ	1Ω - 2MΩ			±25 ±50
SMDT1206	1/8W	-55 ~ +155°C	150V	300V	4.7Ω - 1MΩ	4.7Ω - 2M49Ω	1Ω - 2M49Ω			±25
SMDT1210	1/4W									±50
SMDT2010	1/4W	-55 ~ +155°C	150V	300V	4.7Ω - 1MΩ	4.7Ω - 3MΩ	1Ω - 3MΩ			±25
SMDT2512	1/2W									±50

Operating Voltage= $\sqrt{P \cdot R}$ or Max. operating voltage listed above, whichever is lower.

Overload Voltage= $2.5 \cdot \sqrt{P \cdot R}$ or Max. overload voltage listed above, whichever is lower.

electronic sensor + resistor is capable of manufacturing the optional spec based on customer's requirement.

■ Lower Resistance: 1~10Ω

SMD - Resistors

▶ 7.1 Special Electrical Specifications

Item Type	Power Rating at 70°C	Operating Temp. Range	Max. Operating Voltage	Max. Overload Voltage	Resistance Range						TCR (PPM/°C)
					±0.01%	±0.05%	±0.1%	±0.25%	±0.5%	±1%	
SMDT0402	1/16W	-55 ~ +155°C	25V	50V	49.9Ω - 4.99KΩ		-				±1; ±2; ±3
					49.9Ω - 20KΩ						±5
					49.9Ω - 20KΩ		49.9Ω - 100KΩ		49.9Ω - 69.8KΩ		±10
SMDT0603	1/16W	-55 ~ +155°C	50V	100V	24.9Ω - 15KΩ		-				±1; ±2; ±3
					24.9Ω - 60KΩ						±5
					24.9Ω - 100KΩ	4.7Ω - 332KΩ	4.7Ω - 511KΩ				±10 ±15
SMDT0805	1/10W	-55 ~ +155°C	100V	200V	24.9Ω - 30KΩ		-				±1; ±2; ±3
					24.9Ω - 150KΩ						±5
					24.9Ω - 200KΩ	4.7Ω - 1MΩ				±10 ±15	
SMDT1206	1/8W	-55 ~ +155°C	150V	300V	24.9Ω - 49.9KΩ		-				±1; ±2; ±3
					24.9Ω - 300KΩ						±5
					24.9Ω - 499KΩ	4.7Ω - 1.5MΩ				±10 ±15	
SMDT1210	1/4W	-55 ~ +155°C	150V	300V	24.9Ω - 49.9KΩ		-				±1; ±2; ±3
					24.9Ω - 49.9KΩ						±5
					24.9Ω - 499KΩ	4.7Ω - 1MΩ				±10 ±15	
SMDT2010	1/4W	-55 ~ +155°C	150V	300V	24.9Ω - 100KΩ		-				±1; ±2; ±3
					24.9Ω - 300KΩ						±5
					24.9Ω - 499KΩ	4.7Ω - 1MΩ				±10 ±15	
SMDT2512	1/2W	-55 ~ +155°C	150V	300V	24.9Ω - 100KΩ		-				±1; ±2; ±3
					24.9Ω - 300KΩ						±5
					24.9Ω - 499KΩ	4.7Ω - 1MΩ				±10 ±15	

Operating Voltage= $\sqrt{P \cdot R}$ or Max. operating voltage listed above, whichever is lower.

Overload Voltage= $2.5 \cdot \sqrt{P \cdot R}$ or Max. overload voltage listed above, whichever is lower.

SMD - Resistors

► 7.2 High Power Rating Electrical Specifications

Item Type	Power Rating at 70°C	Operating Temp. Range	Max. Operating Voltage	Max. Overload Voltage	Resistance Range						TCR (PPM/°C)
					±0.01%	±0.05%	±0.1%	±0.25%	±0.5%	±1%	
AR02 (0402)	1/10W	-55 ~ +155°C	50V	100V	49.9Ω - 4.99KΩ						±1; ±2; ±3
					49.9Ω - 4.99KΩ						±5
					49.9Ω - 12KΩ		49.9Ω - 60KΩ				±10
							49.9Ω - 69.8KΩ				±15
-	49.9Ω - 12KΩ	10Ω - 255KΩ	4.7Ω - 255KΩ				±25 ±50				
AR03 (0603)	1/10W	-55 ~ +155°C	75V	150V	24.9Ω - 15KΩ		-				±1; ±2; ±3
					24.9Ω - 15KΩ						±5
					24.9Ω - 100KΩ	4.7Ω - 332KΩ	4.7Ω - 332KΩ				±10 ±15
	4.7Ω - 1MΩ						±25 ±50				
1/6W	-55 ~ +155°C	100V	150V	-	10Ω - 332KΩ					±25 ±50	
AR05 (0805)	1/8W	-55 ~ +155°C	150V	300V	24.9Ω - 30KΩ		-				±1; ±2; ±3
					24.9Ω - 30KΩ						±5
					24.9Ω - 200KΩ	4.7Ω - 511KΩ	4.7Ω - 511KΩ				±10
	4.7Ω - 1MΩ						±15				
1/4W	-55 ~ +155°C	150V	300V	-	10Ω - 499KΩ					±25 ±50	
AR06 (1206)	1/4W	-55 ~ +155°C	200V	400V	24.9Ω - 49.9KΩ		-				±1; ±2; ±3
					24.9Ω - 49.9KΩ						±5
	24.9Ω - 499KΩ	4.7Ω - 1MΩ					±10 ±15 ±25 ±50				
1/3W	-55 ~ +155°C	200V	400V	-	10Ω ~ 1MΩ					±25 ±50	
AR13 (1210)	1/3W	-55 ~ +155°C	200V	400V	24.9Ω - 49.9KΩ		-				±1; ±2; ±3
					24.9Ω - 49.9KΩ						±5
					24.9Ω - 499KΩ	4.7Ω - 1MΩ					±10 ±15 ±25 ±50
AR10(2010)	1/3W	-55 ~ +155°C	200V	400V	24.9Ω - 49.9KΩ		-				±1; ±2; ±3
					24.9Ω - 49.9KΩ						±5
	24.9Ω - 499KΩ	4.7Ω - 1MΩ					±10 ±15 ±25 ±50				
AR12(2512)	3/4W	-55 ~ +155°C	200V	400V	24.9Ω - 2KΩ	4.7Ω - 2KΩ		1Ω - 2KΩ			±10 ±15 ±25 ±50
	1W	-55 ~ +155°C	200V	400V	-	4.7Ω - 100Ω	1Ω - 100Ω				±25 ±50

Operating Voltage= $\sqrt{P \cdot R}$ or Max. operating voltage listed above, whichever is lower.
 Overload Voltage= $2.5 \cdot \sqrt{P \cdot R}$ or Max. overload voltage listed above, whichever is lower.
 electronic sensor + resistor capable of manufacturing the optional spec based on customer's requirement.

■ Lower Resistance: 1-10Ω ; High Power Rating

SMD - Resistors

8. Environmental Characteristics

Item	Requirement		Test Method
	Tol. ≤ 0.05%	Tol. > 0.05%	
Temperature Coefficient of Resistance (T.C.R.)	As Spec.		MIL-STD-202F Method 304 +25/-55/+25/+125/+25°C
Short Time Overload	ΔR±0.05%	ΔR±0.2%	JIS-C-5201-1 5.5 RCWV*2.5 or Max. overload voltage for 5 seconds
	ΔR±0.2% for high power rating		
Insulation Resistance	>9999 MΩ		MIL-STD-202F Method 302 Apply 100V _{DC} for 1 minute
Endurance	ΔR±0.05%	ΔR±0.2%	MIL-STD-202 Method 108A 70±2°C, RCWV for 1000 hrs with 1.5 hrs "ON" and 0.5 hrs "OFF"
	>7kΩ ΔR±0.5%		
	ΔR±0.5% for high power rating		
Damp Heat with Load	ΔR±0.05%	ΔR±0.3%	MIL-STD-202 Method 103B 40±2°C, 90~95% R.H. RWCV for 1000 hrs with 1.5 hrs "ON" and 0.5 hrs "OFF"
	ΔR±0.5% for high power rating		
Bending Strength	ΔR±0.05%	ΔR±0.2%	JIS-C-5201-1 6.1.4 Bending amplitude 3 mm for 10 seconds
Solderability	95% min. coverage		MIL-STD-202 Method 208H 245±5°C for 3 seconds
Resistance to Soldering Heat	ΔR±0.05%	ΔR±0.2%	MIL-STD-202 Method 210E 260±5°C for 10 seconds
Dielectric Withstand Voltage	By Type		MIL-STD-202 Method 301 Max. overload voltage for 1 minute
Thermal Shock	ΔR±0.05%	ΔR±0.25%	MIL-STD-202 Method 107G -55°C ~150°C, 100 cycles
Low Temperature Operation	ΔR±0.05%	ΔR±0.2%	JIS-C-5201-1 7.1 1 hour, -65°C, followed by 45 minutes of RCWV
	ΔR±0.5% for high power rating		
Low Temperature Exposure	ΔR±0.5%		MIL-STD-202 Method 108 at 155°C for 1000 hrs

RCWV(Rated continuous working voltage)= $\sqrt{P \cdot R}$ or Max. operating voltage whichever is lower.

■ Storage Temperature: 25±3°C; Humidity < 80%RH

9. Reflow

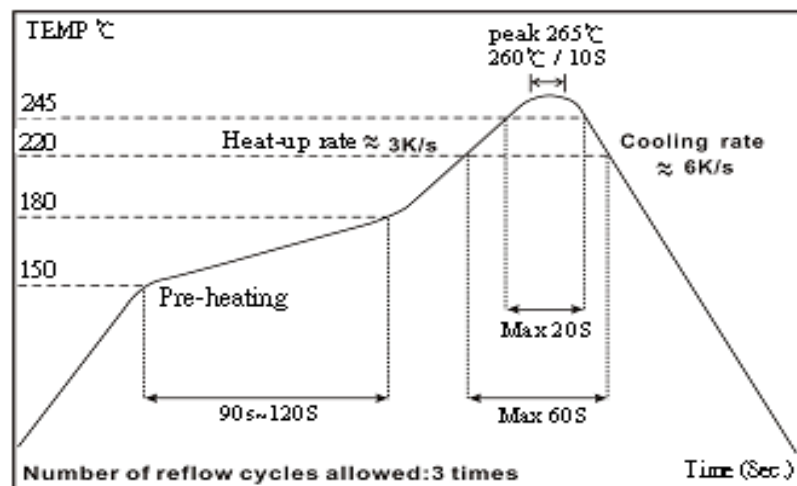

SMD - Resistors

▶ 10. Marking

0603 3digit marking



3digit marking for Example: 14C=13K7Ω 13C=13K3Ω

68B=4K99Ω 68X=49.9Ω

Marking Table

Code	E96	Code	E96	Code	E96	Code	E96				
01	100	25	178	49	316	73	562				
02	102	26	182	50	324	74	576				
03	105	27	187	51	332	75	590				
04	107	28	191	52	340	76	604				
05	110	29	196	53	348	77	619				
06	113	30	200	54	357	78	634				
07	115	31	205	55	365	79	649				
08	118	32	210	56	374	80	665				
09	121	33	215	57	383	81	681				
10	124	34	221	58	392	82	698				
11	127	35	226	59	402	83	715				
12	130	36	232	60	412	84	732				
13	133	37	237	61	422	85	750				
14	137	38	243	62	432	86	768				
15	140	39	249	63	442	87	787				
16	143	40	255	64	453	88	806				
17	147	41	261	65	464	89	825				
18	150	42	267	66	475	90	845				
19	154	43	274	67	487	91	866				
20	158	44	280	68	499	92	887				
21	162	45	287	69	511	93	909				
22	165	46	294	70	523	94	931				
23	169	47	301	71	536	95	953				
24	174	48	309	72	549	96	976				
Code	A	B	C	D	E	F	G	H	X	Y	Z
Multiplier	10 ⁰	10 ¹	10 ²	10 ³	10 ⁴	10 ⁵	10 ⁶	10 ⁷	10 ⁻¹	10 ⁻²	10 ⁻³

0603 3digit marking for E24

Example: 101=100Ω 102=1KΩ

E24	10	11	12	13	15	16	18	20	22	24	27	30	33	36	39	43	47	51	56	62	68	75	82	91
-----	----	----	----	----	----	----	----	----	----	----	----	----	----	----	----	----	----	----	----	----	----	----	----	----

0805~2512 4digit marking

Example

Resistance	100Ω	2.2KΩ	10KΩ	49.9KΩ	100KΩ
marking	1000	2201	1002	4992	1003

SMD - Resistors

► 11. Packaging

Packing Quantity & Reel Specifications

Unit :mm

Type	ØA	ØB	ØC	W	T	Paper Tape (EA)	Emboss Plastic Tape (EA)
SMDT0201	178.0±1.0	60.0±1.0	13.5±0.7	9.5±1.0	11.5±1.0	10,000	-
SMDT0402	178.0±1.0	60.0±1.0	13.5±0.7	9.5±1.0	11.5±1.0	10,000	-
SMDT0603	178.0±1.0	60.0±1.0	13.5±0.7	9.5±1.0	11.5±1.0	5,000	-
SMDT0805	178.0±1.0	60.0±1.0	13.5±0.7	9.5±1.0	11.5±1.0	5,000	-
SMDT1206	178.0±1.0	60.0±1.0	13.5±0.7	9.5±1.0	11.5±1.0	5,000	-
SMDT1210	178.0±1.0	60.0±1.0	13.5±0.7	9.5±1.0	11.5±1.0	5,000	-
SMDT2010	178.0±1.0	60.0±1.0	13.5±0.7	13.5±1.0	15.5±1.0	-	4,000
SMDT2512	178.0±1.0	60.0±1.0	13.5±0.7	13.5±1.0	15.5±1.0	-	4,000

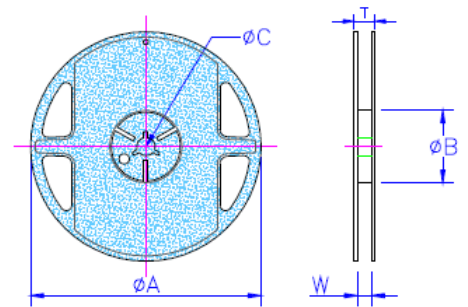

Paper Tape Specifications

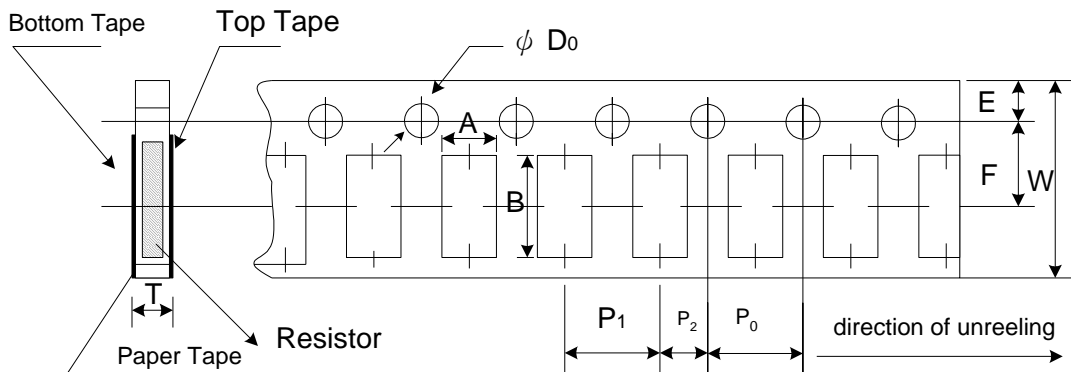

Unit: mm

Type	A	B	W	E	F	P ₀	P ₁	P ₂	ΦD ₀	T
SMDT0201	0.40±0.05	0.70±0.05	8.00±0.10	1.75±0.05	3.5±0.05	4.00±0.10	2.00±0.05	2.00±0.05	1.55±0.03	0.42±0.02
SMDT0402	0.70±0.05	1.16±0.05	8.00±0.10	1.75±0.05	3.5±0.05	4.00±0.10	2.00±0.05	2.00±0.05	1.55±0.05	0.40±0.03
SMDT0603	1.10±0.05	1.90±0.05	8.00±0.10	1.75±0.05	3.5±0.05	4.00±0.10	4.00±0.10	2.00±0.05	1.55±0.05	0.60±0.03
SMDT0805	1.60±0.05	2.37±0.05	8.00±0.10	1.75±0.05	3.5±0.05	4.00±0.10	4.00±0.10	2.00±0.05	1.55±0.05	0.75±0.05
SMDT1206	2.00±0.05	3.55±0.05	8.00±0.10	1.75±0.05	3.5±0.05	4.00±0.10	4.00±0.10	2.00±0.05	1.55±0.05	0.75±0.05
SMDT1210	2.75±0.05	3.40±0.05	8.00±0.10	1.75±0.05	3.5±0.05	4.00±0.05	4.00±0.10	2.00±0.05	1.60±0.10	0.75±0.05

SMD - Resistors

- Peel force of top cover tape
- The peel speed shall be about 300mm/min±5%
- The peel force of top cover tape shall be between 8gf to 60gf

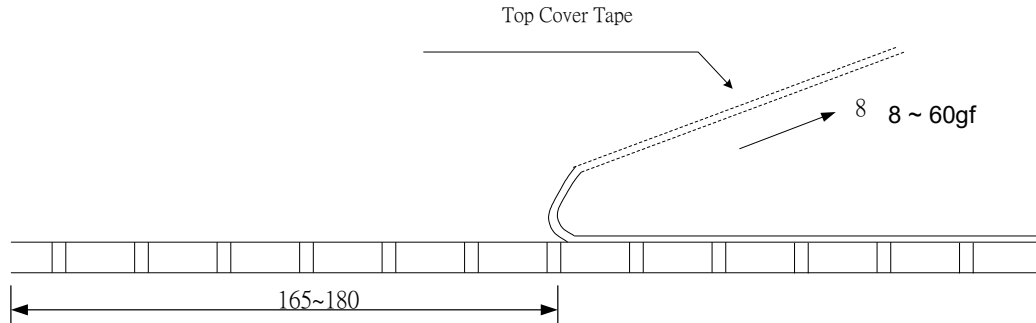

Emboss Plastic Tape Specifications

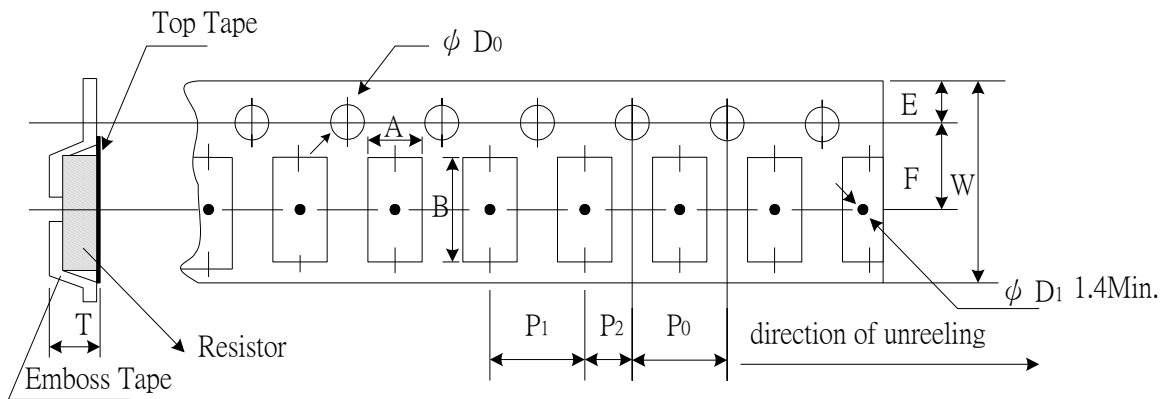

Unit: mm

Type	A	B	W	E	F	P ₀	P ₁	P ₂	ØD ₀	T
SMDT2010	2.85±0.10	5.45±0.10	12.0±0.10	1.75±0.10	5.5±0.05	4.00±0.05	4.00±0.10	2.00±0.05	1.50+0.10	1.00±0.20
SMDT2512	3.40±0.10	6.65±0.10	12.0±0.10	1.75±0.10	5.5±0.05	4.00±0.05	4.00±0.10	2.00±0.05	1.50+0.10	1.00±0.20

- Peel force of top cover tape
- The peel speed shall be about 300mm/min±5%
- The peel force of top cover tape shall be between 20gf to 80gf

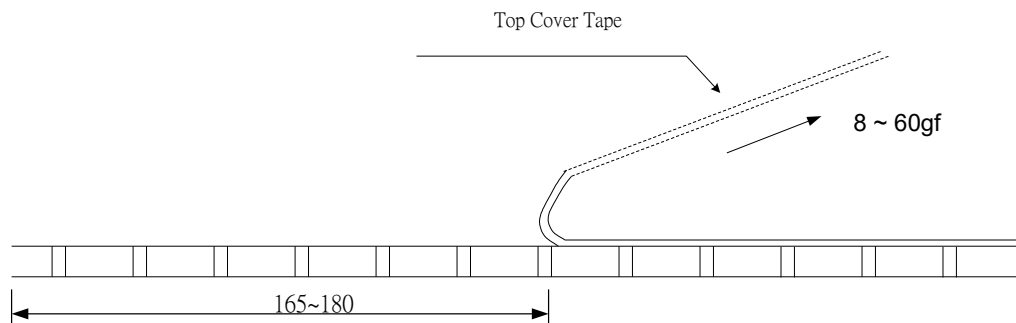

SMD - Resistors

▶ 12. Recommended Land Pattern

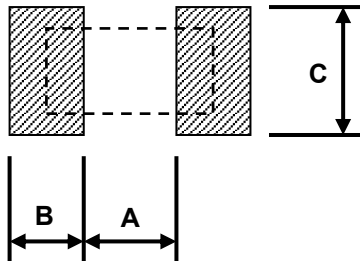

Unit: mm

Type	A	B	C
SMDT0201	0.25	0.30	0.40±0.2
SMDT0402	0.50	0.50	0.60±0.2
SMDT0603	0.80	1.00	0.90±0.2
SMDT0805	1.00	1.00	1.35±0.2
SMDT1206	2.00	1.15	1.70±0.2
SMDT1210	2.00	1.15	2.50±0.2
SMDT2010	3.60	1.40	2.50±0.2
SMDT2512	4.90	1.60	3.10±0.2